



*Leading Optical Innovations*

# 432 Outdoor Fiber Distribution Cabinets Installation Manual

**COPYRIGHT**

© 2011, Furukawa Electric North America, Inc.  
All Rights Reserved  
Printed in the U.S.A

**REVISION HISTORY**

Issue 1                      August 18, 2011                      Original Release Date

**TRADEMARK INFORMATION**

OFS is trademark of Furukawa Electric North America, Inc.

**DISCLAIMER OF LIABILITY**

The contents of this document as of the date of publication are current. OFS reserves the right to change the contents without prior notice. OFS in no way will be liable for any damages resulting from loss of information, use or profits. OFS further disclaims all liability direct or indirect, consequential or incidental for all product, publications and services during and after the warranty period.

TABLE OF CONTENTS

About this Manual	3
Product Overview	3
Product Specifications	5
Warnings	6
Inspecting Shipment	6
Replacement and Accessory Kits	6
Installation	7
Pole Mounting	7
Pad Installation	10
Grounding	14
Fiber Routing	16
Customer Information and Assistance	17

### ***About This Manual***

This document details the 432 Outdoor Fiber Distribution Cabinet. The details of mounting/installation of the cabinet, fiber splitter installation, fiber jumper arrangement, jumper tracing and general maintenance are also covered.

### ***Product Overview***

The 432 Outdoor FDC is available in a 432 port configurations. The 432 FDC cabinet can either be pad mounted or pole mountable outdoor. The 432 FDC cabinet has overall dimensions of 36 inches in height, 18 inches in depth, and 24 inches in width (Figure 4).

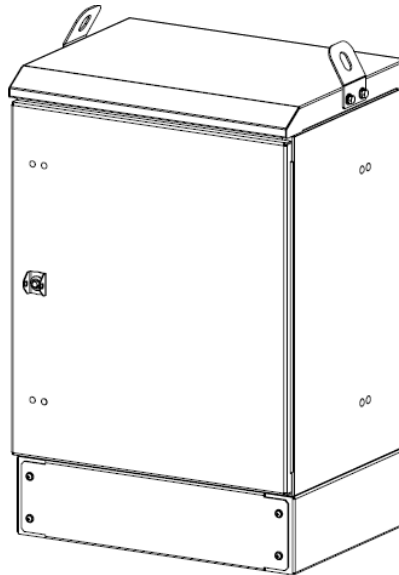

Figure 1: 432 Outdoor Fiber Distribution Cabinet

A 432 Fiber Distribution Cabinet is constructed of aluminum with a powder coat painted finish for reduced weight and superior corrosion resistance. The front door and rear access panel are equipped with quarter turn padlock latches. The top of the cabinet has a double wall construction for structural integrity. A six (6") inch high plinth and a thirty six (36") are provided under the equipment bay for pad mounting.

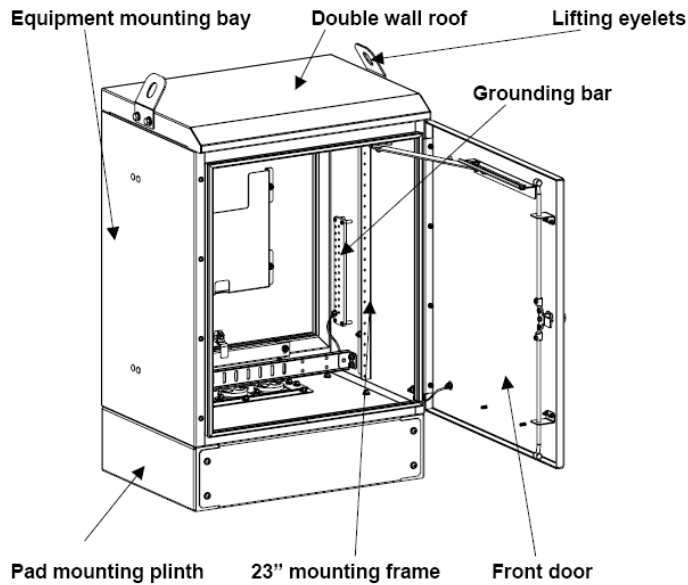

Figure 3: Front View of Cabinet

The front section houses fiber optic equipment and is provided with 23" wide rack space. The rear section is used for cable ingress and egress.

Cable entry and exit from the cabinet passes through the split seals located in the bottom rear section of the equipment bay. Removable panels are provided at the base of the cabinet, which allow the cabinet to be slid over the input and output cables without threading the cables through the cabinet. Split seals can be slid over the cables without threading the cables through the seals.

The master grounding bar is located in the rear section of the equipment bay. See the cabinet grounding sections of this document for grounding instructions.

**Product Specifications**

**432 Fiber Distribution Cabinet**

- Approximate cabinet outer physical dimensions:
- Height – 36 inches
- Width – 24 inches
- Depth – 18 inches
- Approx. Weight – 80 pounds

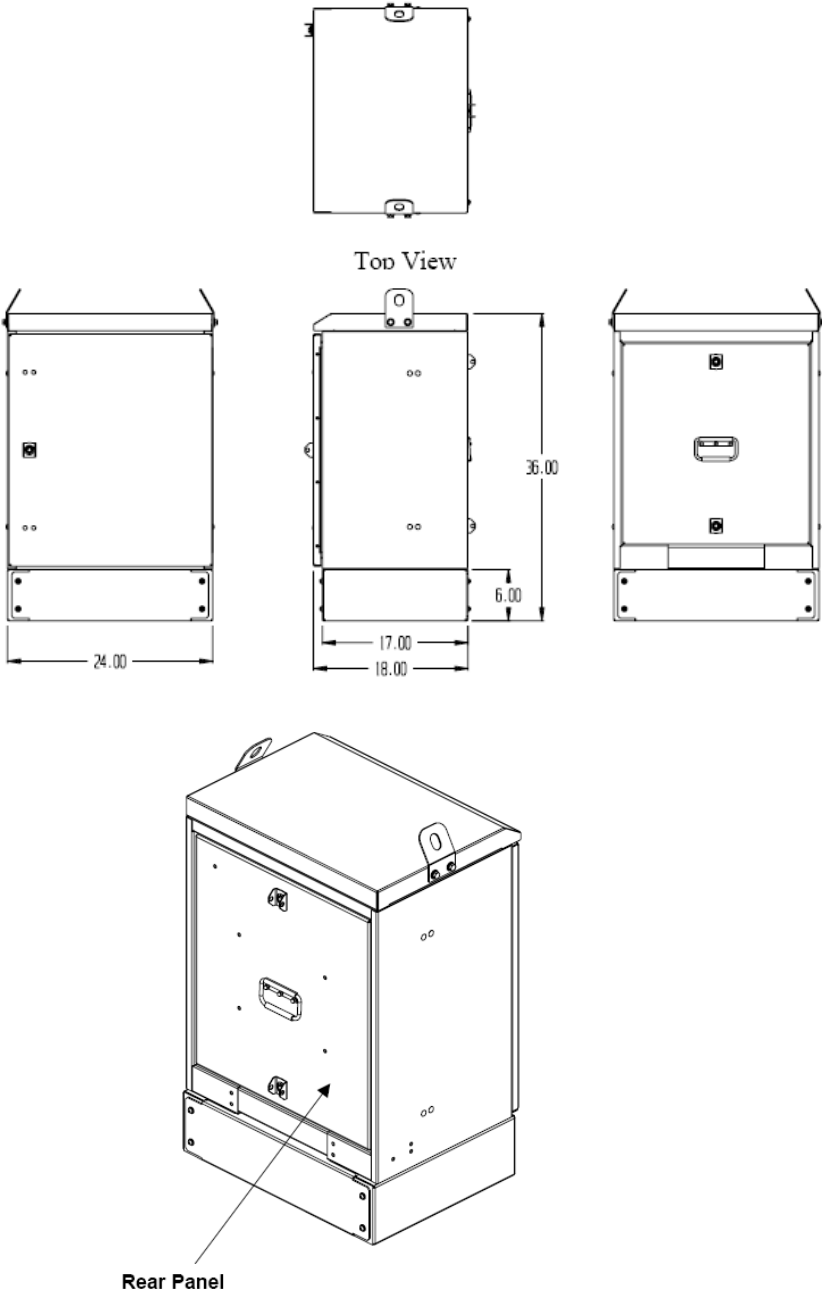

Figure 4: Rear view of cabinet showing rear panel

## Warnings

Important safety warnings are used throughout this manual for possible hazards to persons and equipment. A warning identifies a possible hazard and then explains what may happen if the hazard is not avoided. These cautions should be followed at all times. These warnings are flagged by use of triangular alert icon (see below) and are listed in descending order of severity of injury or damage and likelihood of occurrence.



**Note** - indicates special conditions.



**Caution** - indicates possibility of personal injury or equipment damage.

### **Inspecting Shipment**

Upon receipt of the equipment, following the following instructions:

- (1) Inspect the shipping containers and note any signs of damage.
- (2) Unpack the containers and carefully inspect the contents for damage.
- (3) If the equipment has been damaged in transit, immediately report the extent of the damage to the transportation company and to OFS. Order replacement equipment if necessary.
- (4) Check the packing list to ensure complete and accurate shipment of all listed items.
- (5) If the packing list is irregular or deficient in any way, please contact OFS as described in the Warranty agreement.
- (6) Prolonged storage of the equipment should be done the original container.
- (7) Product returns should use the original packaging if available.

### **Replacement and Accessory Kits**

See Table 1 for replacement and accessory kit details. See your local OFS account representative for order details on the accessory kits.

Description	Kit Quantity
Equipment mounting hardware kit	1
Latch rear panel	1
Seal cabinet door	
Foam tape 1/8" x 1/2"	Roll
Seal, 2 port, cable entry	3
Door Latch	
Installation Manual	1

Table 1: Replacement and Accessory Kit Contents

**Installation Instructions**

432 Outdoor Fiber Distribution Cabinet can be pole mounted or pad mounted.

*Pole Mounting*

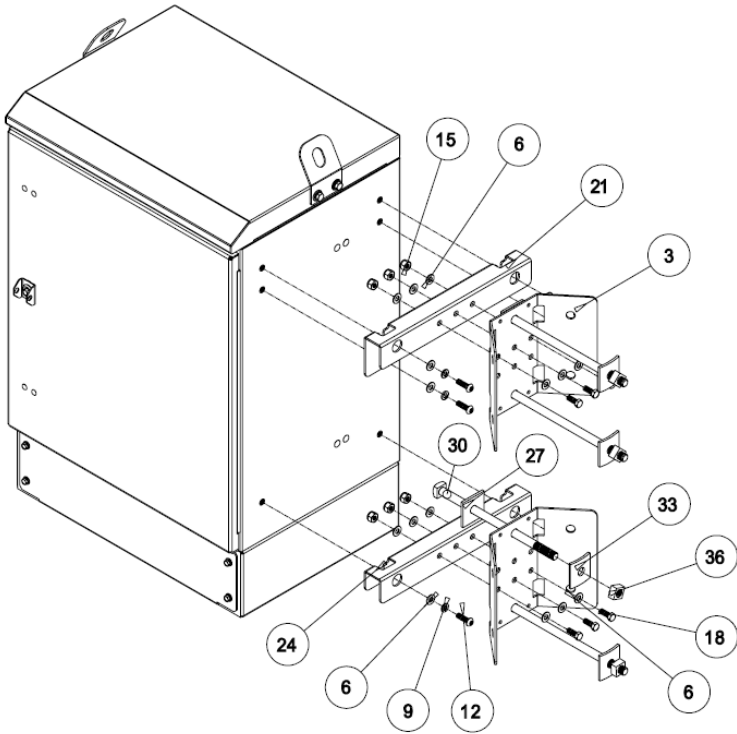

Figure 6: Pole Mounting Diagram



ITEM NO.	QTY.	PART NUMBER	DESCRIPTION
003	2	S10500-182	Bracket, Vertical Pole Mount, Universal
006	18	H38NS6SFWNPMC	Washer, 3/8" X 3/4" MP06G 316 SS Flat
009	6	H38NS6SLWSPMC	Washer, 3/8" MP06G 316 SS Split Lock
012	6	H38C125S6SMSARMC	Bolt, 3/8-16 x 1.25 MP06G 316 SS Pinned Button Head
015	6	H38CPSLNNIZ	Nut, Nylon Top Lock 3/8"
018	6	H38C100SSMSHH	Screw, 3/8-16 x 1", Stainless Steel, Cap
021	1	S10025-042	Bracket, Upper Pole Mount
024	1	S10025-043	Bracket, Lower Pole Mount
027	4	H63NPSSWGV	Washer, Square, 2 1/4 x 2 1/4 x 3/16, 5/8, Galvanized
030	4	H63C1600PSSHGV	Bolt, Square Head, 5/8-11 x 16 & Nut, Galvanized
033	4	H63NPSCWGV	Washer, Curved, 2 1/4 x 2 1/4 x 3/16, 5/8, Galvanized
036	4	H63NUT	Nut, 5/8, Galvanized (Included with Bolt)

**Table 2: Pole Mounting Kit Bill of Materials**

**POLE INSTALLATION DRAWING**

Shown below are the overall dimensions of the cabinet with the pole mounting brackets installed on the cabinet.

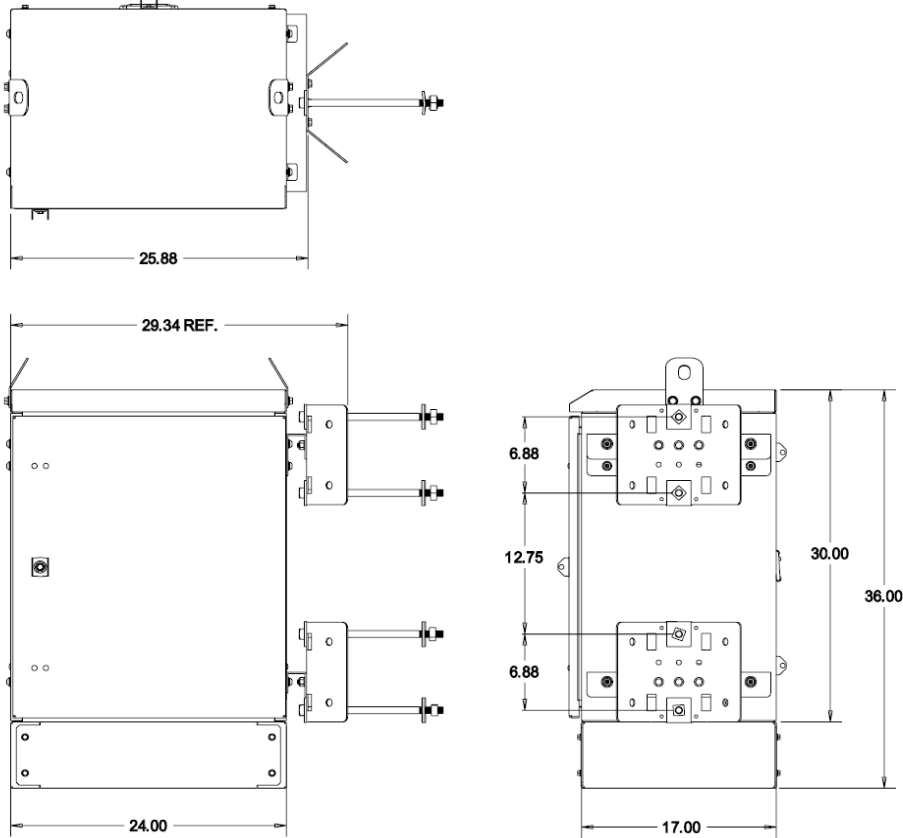

**Figure 7: Dimensions for Pole Mounting**



## **Pole Mounting Installation Procedures**

Use this procedure to mount the cabinet on an 8 to 14 inch diameter wooden pole. See figures 6 and 7 on previous pages.



Have the following equipment ready before beginning this procedure:

- One drill
  - One  $\frac{3}{4}$ " (19.05 mm) x 12" (30.5 cm) drill bit
  - One  $\frac{9}{16}$ " wrench
  - Two  $\frac{15}{16}$ " wrenches
  - A pencil
  - Optional small pole mounting kit
1. Pre-assemble the upper and lower horizontal brackets to the vertical brackets as shown in the figures on the preceding pages.
  2. Select a convenient mounting location on the pole.
  3. Install the pole mounting template as an aid. Drill four (4)  $\frac{3}{4}$ " diameter holes in the pole per the dimensions in Figure 7 for the four (4)  $\frac{5}{8}$ " bolts (item 30 in Figure 6).
  4. Insert machine bolt (item 30) through mounting bracket and into the mounting hole and press bolt and bracket flush against the pole.
  5. Place round-cupped washer (item 33), with the concave side in, on bolt and finger tighten nut.
  6. Repeat step 4 and 5 for remaining bolts.
  7. Secure the mounting bracket assemblies to the pole by securely tightening the machine bolts to 40 ft-lbs for wooden posts.
  8. Holes are provided in the side of the vertical brackets for lag bolt installation for larger poles. The brackets can also be banded to metal poles.
  9. Engage the four (4)  $\frac{3}{8}$ " cap screws (item 12), which slide into the keyed slots provided in the horizontal brackets, into the cabinet as shown in the diagram.
  10. Using proper lifting and safety equipment, place cabinet on mounting bracket assemblies using supplies  $\frac{3}{8}$ " hardware and tighten to 45 ft-lbs. Lifting eyelets are provided on the cabinet for hoisting it in place.

11. Once cabinet is securely in place, install the remaining 3/8" cap screws (item 12) on the upper pole mount bracket.
12. If the cable stubs connect to an underground cable, dress the cable down the pole. If the cable stubs connect to an aerial cable, form a drip loop in the cable and dress it up the pole to the splice case.

-  **For mounting heights less than 7' above grade, excess bolt length may need to cut off in order to prevent a hazardous protrusion.**
-  **Due to the cabinet's weight and size, mounting of the cabinet will require proper hoisting equipment. Lifting eyelets are provided facilitate hoisting.**

### *Pad Installation*

-  **Due to the cabinet's weight and size, mounting of the cabinet will require proper hoisting equipment. Lifting eyelets are provided to facilitate hoisting.**
-  **During cabinet mounting, fixture the cabinet securely to avoid personal injury or cabinet damage.**

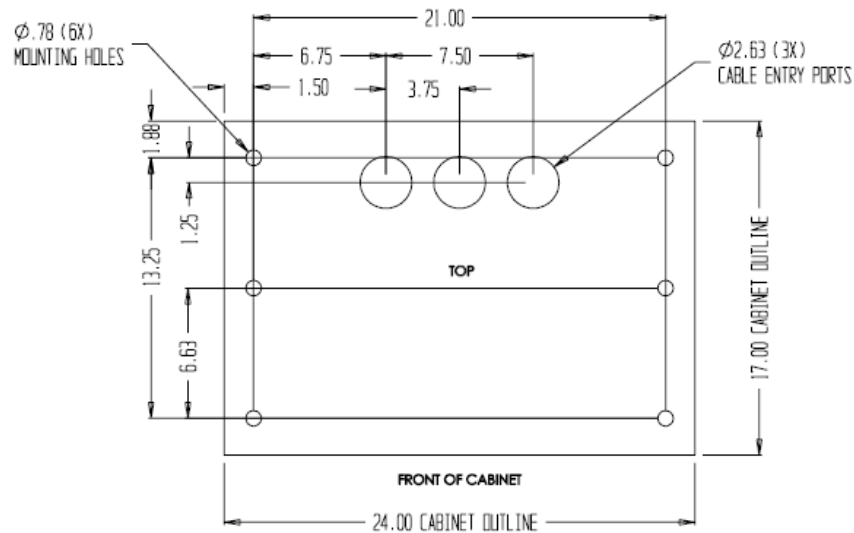

Figure 8: 432 Cabinet Mounting Template

### *Clearance Requirements*

When selecting a location to mount the cabinet, ensure that proper clearance is available to allow adequate ventilation and to allow the cabinet door to open fully. The cabinet footprint with door open is shown below (from the top view).

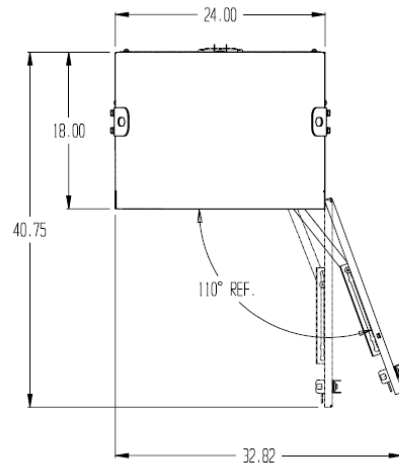

Figure 10: Cabinet Footprint

The 432 Fiber Distribution Cabinet does **not** require the threading of input and output cables through the base of the cabinet. The cable entry area can be found at the rear of the cabinet. Removable panels are provided at the base of the cabinet, which allow the cabinet to be slid over the input and output cables. Split seals can be slid over the cables without threading the cables through the seals (see following figures).

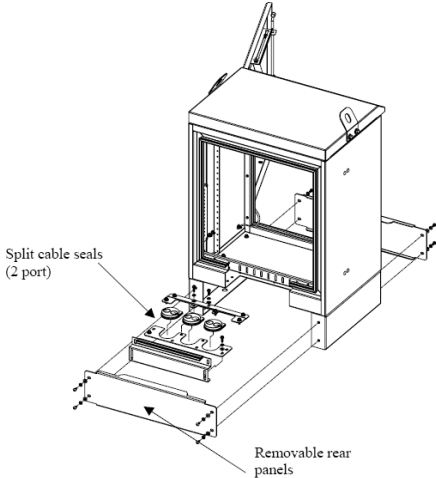

Figure 11: Cable Entry Area, Rear View

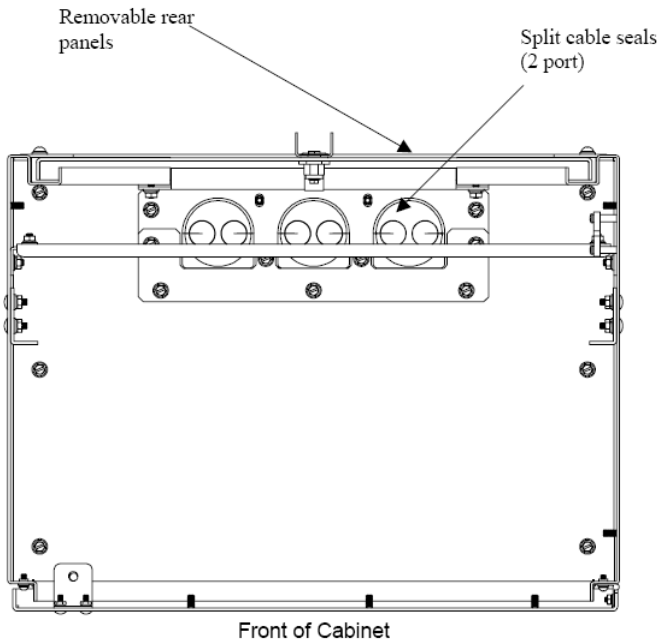

Figure 12: Top View of Cable Entry Area

### ***Pad Installation Procedures***

Have the following equipment ready before beginning this procedure:

1. One masonry drill
2. One 5/8" (15.9 mm) masonry drill bit
3. Masonry expansion anchors
4. One 9/16" wrench
5. A pencil
6. One Hammer

Use the procedure below to mount the cabinet on an existing concrete slab.

1. Position the provided template on the slab in the desired location for the cabinet and mark the location of the mounting holes with respect to the cable entry area.
2. Place the template out of the way.
3. Drill 5/8" (15.9 mm) diameter by 3" (7.62 cm) deep holes at the locations marked in step 2.
4. Insert anchor bolts into the holes in the slab and tap them firmly into the holes with a hammer.
5. Remove the nuts and washers from the expansion anchors.
6. Remove the rear panels and seals from the cable entry area of the cabinet.
7. Remove the mounting bolt access covers from the plinth.
8. Place the cabinet over the studs and reinstall nuts and washers. Secure the cabinet to the slab by securely tightening all anchor bolts to 40 ft-lbs or as recommended by the expansion anchor manufacturer.
9. Reinstall the mounting bolt access covers on the plinth.
10. Remove portion of the cable entry seals corresponding to the diameters of the cables. Install the split cable seals around the cables and slide them down the cables to the base of the cabinet.
11. Reinstall the cable entry panels.

## **Cabinet Grounding Information**

Bonding and grounding should be done in accordance with the operating telephone company's standard procedures and comply with local electrical codes.

### *Ground Wire*

The ground wire protects the electronics from voltage surges. A #6 ground wire must be properly grounded to provide lightning surge protection for the cabinet. Please follow this practice for attaching the ground unless local policies dictate otherwise.

For safety and performance reasons it is imperative that a cabinet be properly grounded. The following guidelines should be used to ground the cabinet unless local practices, rules, or regulations dictate otherwise.

Each door and equipment rack is grounded to the cabinet frame. The cabinet frame is connected to the internal grounding bus by a stranded wire. A similar ground wire must be used to connect the ground bus to each equipment ground lug. These ground wires may need to be removed temporarily to troubleshoot ground faults. The wire may be removed by unscrewing the screws that secure the green wire to the ground bus. ***Be sure to reattach these wires after troubleshooting and resolving any ground conflicts.***

Be sure to ground the cabinet before connecting power to the cabinet. This grounding must be in effect at all times to safeguard personnel.

*Installation Procedures*

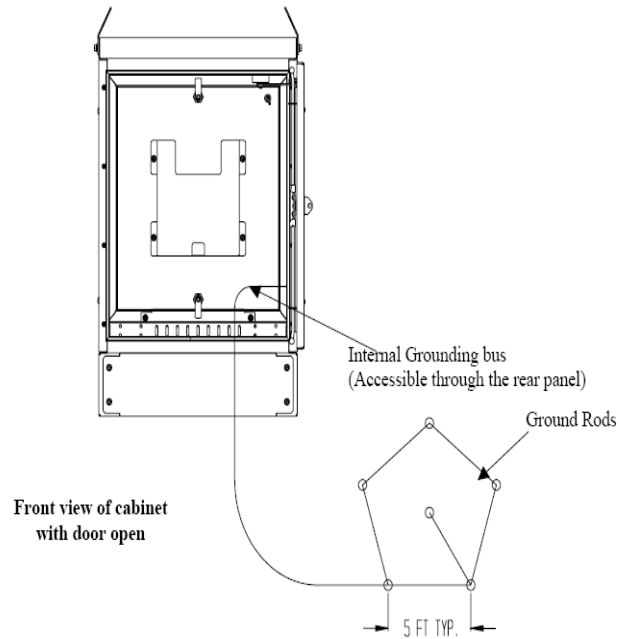

Figure 13: Grounding Diagram

To ground the cabinet, use the following procedures and diagram above (Figure 13):

1. Drive the ground rods into the ground near the cabinet location.
2. Use a Megger-type Ohmmeter to measure the resistance between the cabinet ground and the ground rods. The resistance must be 25 ohms or less.
3. If the ohm requirement in step 3 is met, please proceed to step 4. Otherwise, follow local practices to lower the resistance to ground to comply with 25 ohms before proceeding to step 4.
4. Connect a #6 ground wire to the ground rods.



**Fiber Routing**

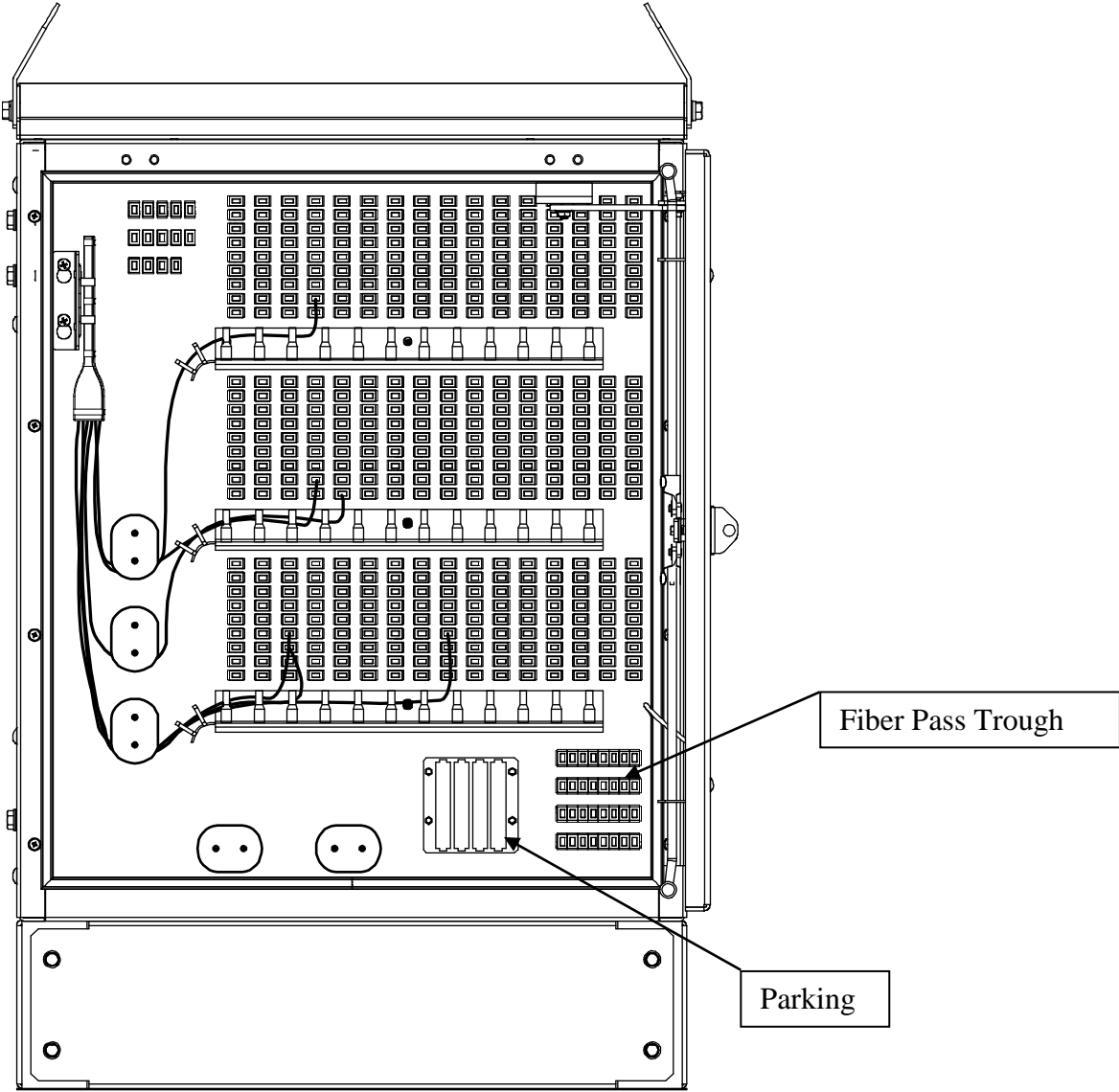

Fig. 14 432 Fiber Distribution Cabinet – Fiber routing

When routing the pigtailed optimize the cable slack by choosing appropriate bend control guides. Avoid cable kinking and pulling during the installation. Use the shelves and the rings for keeping the pigtailed organized.

**Vault Options:**

Consult your local distributor for various handhole/vault options.

Current compatible vaults can be found at:

Hubbell/Strongwell  
PG3636Z514 Vault for 432 Fiber Distribution Cabinet  
3621 Industrial Park Dr  
Lenoir City, TN 37771  
(865) 986-9726

Carson Industries  
3048 PC- Undercover Vault for 432 Fiber Distribution Cabinet  
1160 Nicole Court  
Glendora, CA 91760  
(909) 592-6272

**Customer Information and Assistance**

Ordering Entry/Customer Service	1-888-342-3743, Prompt 1
Sales Support	1-888-342-3743, Prompt 2
Technical Support	1-888-342-3743, Prompt 3

Please feel free to contact your Customer Service Representative for any product related issues. Please make available OFS order number, part numbers, and company information at the time of contact.